

FFI RAPPORT

SENSOR INSTALLATION ON KNM SKJOLD PRIOR TO FIRING TESTS APRIL 2000

FARSUND Øystein, SAGVOLDEN Geir, PRAN Karianne, WANG
Gunnar

FFI/RAPPORT-2000/03665

FFIE/793/116

Approved
Kjeller 13 July 2000

Stian Løvold
Director of Research

**SENSOR INSTALLATION ON KNM SKJOLD
PRIOR TO FIRING TESTS APRIL 2000**

FARSUND Øystein, SAGVOLDEN Geir, PRAN
Karianne, WANG Gunnar

FFI/RAPPORT-2000/03665

FORSVARETS FORSKNINGSINSTITUTT
Norwegian Defence Research Establishment
P O Box 25, NO-2027 Kjeller, Norway

FORSVARETS FORSKNINGSINSTITUTT (FFI)
Norwegian Defence Research Establishment

UNCLASSIFIED

P O BOX 25
 NO-2027 KJELLER, NORWAY
REPORT DOCUMENTATION PAGE

SECURITY CLASSIFICATION OF THIS PAGE
 (when data entered)

1) PUBL/REPORT NUMBER FFI/RAPPORT-2000/03665 1a) PROJECT REFERENCE FFIE/793/116	2) SECURITY CLASSIFICATION UNCLASSIFIED 2a) DECLASSIFICATION/DOWNGRADING SCHEDULE -	3) NUMBER OF PAGES 33										
4) TITLE SENSOR INSTALLATION ON KNM SKJOLD PRIOR TO FIRING TESTS APRIL 2000												
5) NAMES OF AUTHOR(S) IN FULL (surname first) FARSUND Øystein, SAGVOLDEN Geir, PRAN Karianne, WANG Gunnar												
6) DISTRIBUTION STATEMENT Approved for public release. Distribution unlimited. (Offentlig tilgjengelig)												
7) INDEXING TERMS IN ENGLISH: <table style="width: 100%; border: none;"> <tr> <td style="width: 50%; border: none;"> a) <u>Fibre optic sensors</u></td> <td style="width: 50%; border: none;"> IN NORWEGIAN: a) <u>Fiberoptiske sensors</u> </td> </tr> <tr> <td style="border: none;"> b) <u>Accelerometers</u></td> <td style="border: none;"> b) <u>Akselerometre</u> </td> </tr> <tr> <td style="border: none;"> c) <u>Data acquisition</u></td> <td style="border: none;"> c) <u>Datainnsamling</u> </td> </tr> <tr> <td style="border: none;"> d) _____</td> <td style="border: none;"> d) _____ </td> </tr> <tr> <td style="border: none;"> e) _____</td> <td style="border: none;"> e) _____ </td> </tr> </table>			a) <u>Fibre optic sensors</u>	IN NORWEGIAN: a) <u>Fiberoptiske sensors</u>	b) <u>Accelerometers</u>	b) <u>Akselerometre</u>	c) <u>Data acquisition</u>	c) <u>Datainnsamling</u>	d) _____	d) _____	e) _____	e) _____
a) <u>Fibre optic sensors</u>	IN NORWEGIAN: a) <u>Fiberoptiske sensors</u>											
b) <u>Accelerometers</u>	b) <u>Akselerometre</u>											
c) <u>Data acquisition</u>	c) <u>Datainnsamling</u>											
d) _____	d) _____											
e) _____	e) _____											
THESAURUS REFERENCE: 8) ABSTRACT This document describes the installation of resistive strain gauges, Bragg grating strain sensors, pressure sensors and accelerometers prior the cannon firing tests carried out on KNM Skjold in April 2000. Figures of the exact location of sensors, together with digital pictures of several sensor locations are included. The document also provides a discussion of the experience gained during the installation, and recommendations for future installation work												
9) DATE 13 July 2000	AUTHORIZED BY This page only Stian Løvold	POSITION Director of Research										

ISBN-82-464-0455-5

UNCLASSIFIED

SECURITY CLASSIFICATION OF THIS PAGE
 (when data entered)

CONTENTS

1	INTRODUCTION	7
2	INSTALLATION PROCEDURE AND EXPERIENCE GAINED DURING INSTALLATION	8
2.1	Fiber optic sensors	8
2.2	Resistive strain gauges	8
2.3	Pressure sensors	9
2.4	Accelerometers	11
3	SENSOR LOCATIONS	11
3.1	Sensors for the use of measuring local loads due to the blast	12
3.1.1	Panel G	12
3.1.2	Panel H - fore peak	12
3.1.3	Panel 5 and fan compartment	14
3.1.4	Sensor locations in the port fan engine room and port stores	14
3.2	Sensors for estimation of rotations	20
3.2.1	Gun fundament	20
3.2.2	Wheelhouse roof	20
3.2.3	Instrument room (datum)	20
3.2.4	Mast	23
4	COMMENTS	23
4.1	Comments on individual sensor locations	28
	References	30
APPENDIX		
A	DATA CDs	31
	Distribution list	33

SENSOR INSTALLATION ON KNM SKJOLD PRIOR TO FIRING TESTS APRIL 2000

1 INTRODUCTION

This document describes the installation procedures and locations of the sensors installed on KNM Skjold in March 2000 and the experience gained from the installation process. The sensors were installed in order to carry out measurements during the Oto Melara 79 mm cannon firing tests in April 2000. The installations were carried out under a separate contract, and not directly associated with the CHESSE project (1). The type, number of sensors and the purpose of the measurements were:

- 45 resistive strain gauges to measure local loads on selected panels
- 12 fiber optic strain gauges to estimate the rotations of the mast and the load on a gun fundament leg during and after gun fire
- 20 accelerometers to estimate local rotations of the mast, gun fundament, wheelhouse roof and the datum
- 8 pressure sensors to measure pressure on the surface of the most exposed panels, as well as the time course of the pressure in the fan room and port fan engine room.



Figure 1.1 The sensor locations as well as some of the gun firing tests have been taped using a mini-DV camcorder. The photos in this report have been taken from this tape. The picture shows the gun immediately after gun test number 19

The purposes of the measurements were to measure the effect of modifications of the deck, bring to light the pressure load in the lifting fan area and to estimate the relative rotations between the gun, datum and locations where the aiming instrumentation is to be installed.

FiReCo AS defined the firing program and sensor location (2). In the following, the mounting locations are presented using sketches and photographs. Most sensor locations have been video-taped. The tape is available at FFI. All measurement data have been forwarded to FiReCo AS. Back-ups on CDrom are available at FFI.

Much of the material on rotation measurements are based on experience gained during the previous round of tests, see (3).

2 INSTALLATION PROCEDURE AND EXPERIENCE GAINED DURING INSTALLATION

The procedures used for sensor installation are briefly presented in the following.

2.1 Fiber optic sensors

The fiber optic sensors were installed as follows.

On the port-side aft steel pipe of the gun fundament, the installation area was prepared by first manually sanding a 40 cm section of the pipe, followed by washing using acetone. The section was separated from the unwashed sections using Scotch tape. The sanding and washing process was repeated inside the section, before the sensor positions were marked using a permanent ink pen. The fiber array containing the sensors were carefully aligned and taped to the appropriate position, starting with the port side sensor. The 1 m fiber between each sensor was spooled around the the pipe to avoid slack and loose fiber loops. The fiber was glued to the surface using an epoxy (*Araldite 2010*), starting with the sensors but protecting all fiber eventually. The fiber was spliced to a 50m fiber optic cable run in the corridor to the interrogation equipment located in the operations room.

On the mast legs, the sensor areas were marked and sanded using a power sander. The fiber route between the sensor locations were lightly sanded to remove any sharp edges that could induce fiber breakage or loss. The locations were washed using acetone. Fiber optic cable was routed inside the mast legs to the lowest hatch. The 3mm fiber cable was stripped of the outer plastic tube and Kevlar protection, leaving a 0.9 mm fiber. This fiber was pulled through a 1.5 mm hole drilled in the outside face of the mast at the forward corner. The 0.9 mm fiber was fusion spliced to the fiber sensor array. The splice protection tube was taped to the mast, and the surplus 0.9 mm fiber retracted and taped inside the mast. The fiber sensor array was laid out, held by pieces of Scotch tape. The fiber was glued to the mast using (*Araldite 2010*) epoxy, and further protected using *Sikaflex*.



Figure 2.1 Strain gauge mounted on the weather-side of panel G

2.2 Resistive strain gauges

Strain gauges were mounted as follows:

On the deck, the panel edges were found by measuring the distance to features such as the wheelhouse, the lift fan intake and the hull side. The middle points on the panel edge were marked using masking tape. The positions were checked by tapping the deck to locate the bulkheads. The sensor positions were marked, the surface machine sanded and washed with acetone. After measuring and marking the exact sensor position, the strain gauge (TML PFL-20-11-1L) was affixed using cyanoacrylate.

The sensor was protected against moisture and mechanical influence using a viscous putty (AK 22, Hottinger Baldwin Messtechnik). Thereafter, the sensor was connected (two wires per strain gauge) to the cable. In order to reduce electromagnetic noise, the connectors, the unshielded wires as well as the sensor were covered by an aluminum foil (ABM 75 from Hottinger Baldwin Messtechnik) which was grounded to the cable shielding by piercing the foil with the ground cable, see Fig. 2.4. Attempts to solder on the cable were unsuccessful. The cabling from sensor area to the three amplifiers (Hottinger, Micro Movements and Vishey 23211) was laid out by electricians. The cables were laid on deck if possible to reduce the electromagnetic interference. Cables routed inside were strapped to ventilation ducts and kept away from other cables if possible.

2.3 Pressure sensors

Two types of pressure sensors were used. Surface-mounted pressure sensors (EPL-D02-3.5B and EPL-D02-7B, Entran, Fairfield, NJ) were used for measurements on

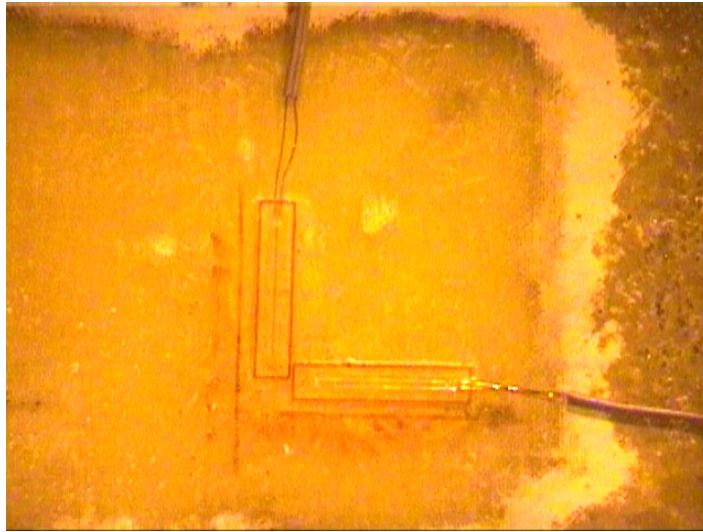

Figure 2.2 Strain gauge 0-90 rosette mounted on the weather-side of panel G

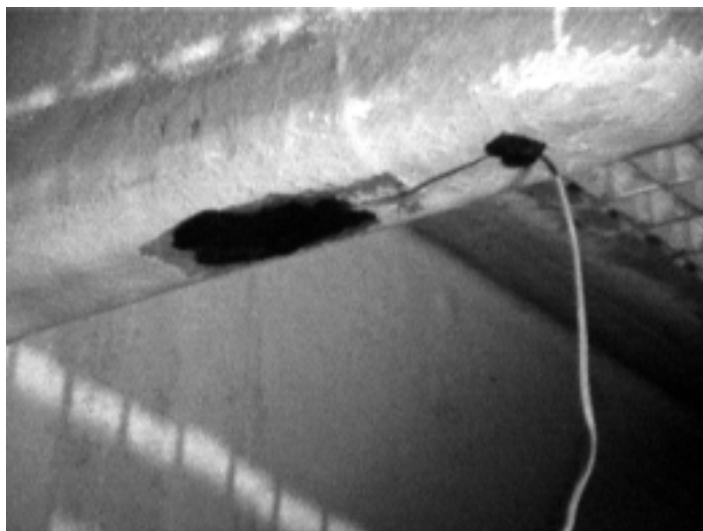

Figure 2.3 Strain gauge covered with AK 22 putty



Figure 2.4 Strain gauge with ABM 75 aluminum shield. Notice the ground wire pierced through the foil

flat surfaces as the deck and walls. They were installed in the same way as the resistive strain gauges, excluding the putty and aluminum foil. The other sensor type (XTE-190, Kulite Semiconductor Products Inc, Leonia, NJ) was mounted in fixtures for free air measurements in the lift fan room or inside ventilation ducts, and in one case on the port lift fan machine room floor. Both types required 4 wires for each sensor (2 for the supply voltage and 2 for the signal). The wires were soldered to the cables. The same type of cables as for the resistive strain gauges were used.

2.4 Accelerometers

Primarily, we wanted to use a jig with pre-installed accelerometer for all rotation measurements. However, this was possible only in the instrument room (datum) and in the mast. On the gun fundament and on the wheelhouse roof, the surfaces were prepared by grinding and washing, then accelerometer cubes (a cube of approximately dimensions 25 mm×25 mm×25 mm) were glued to the surface using cyanoacrylate. Nuts, in which the accelerometers can be screwed, were affixed to the cubes in advance. Outdoors accelerometers were covered in silicon grease protecting against humidity. Special cables from the accelerometer to the battery-powered amplifier (PCB 480E09) were used, and coaxial cables (RG58) was used from the amplifier to the PC in the operations room. Electricians laid out most of the coaxial cable.



Figure 2.5 Two accelerometers mounted on a precision cube glued to the radar fundament using cyanoacrylate glue

3 SENSOR LOCATIONS

The strain gauges on the panels are named in the following way:

<Sensor area name><direction><location>.

The sensor area name is the panel or beam name. The directions are x - fore-and-aft, y - abeam, z - vertical, and the location is either f - fore, a - aft, SB - starboard, BB - port (“babord”) or m - middle. An example is $5oySB$, which is a sensor located on the top side of panel 5, in the y -direction on the starboard side of the panel.

An overview of the sensors located on deck is given in Fig 3.1.

3.1 Sensors for the use of measuring local loads due to the blast

Conventional resistive strain gauges and pressure gauges were used for the purpose of measuring local loads as a result of the blast.

3.1.1 Panel G

This panel is located above the chief’s cabin. Sensor locations on top and underneath this panel are shown in Figs 3.2 and 3.3 respectively. The installation underneath had to be slightly offset in order to accommodate nails holding sound and fire insulation panels in the roof.

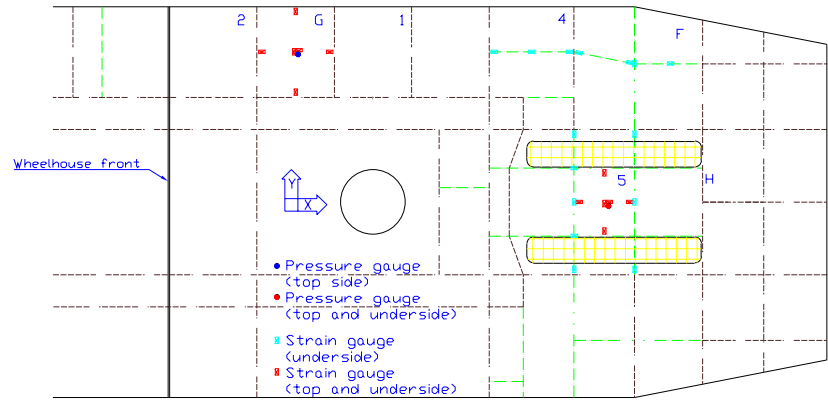

Figure 3.1 Overview of the strain gauges on the top and underside of the weather deck

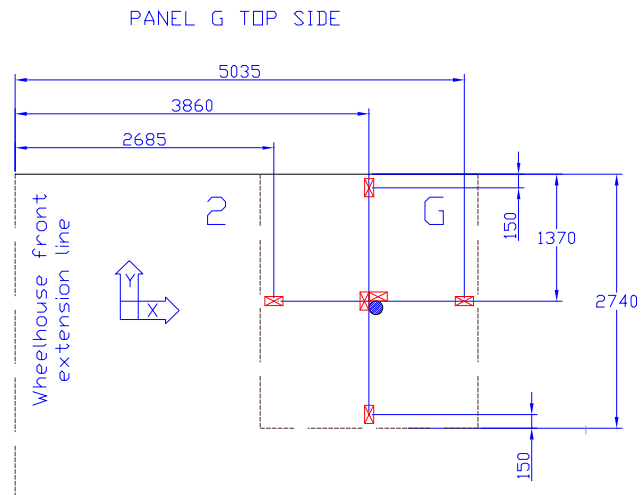

Figure 3.2 Strain gauge installations on the top side of panel G. The fore-and-aft measurements were given from the intersection of the wheelhouse and the deck. The transverse measurements are from the side of the hull

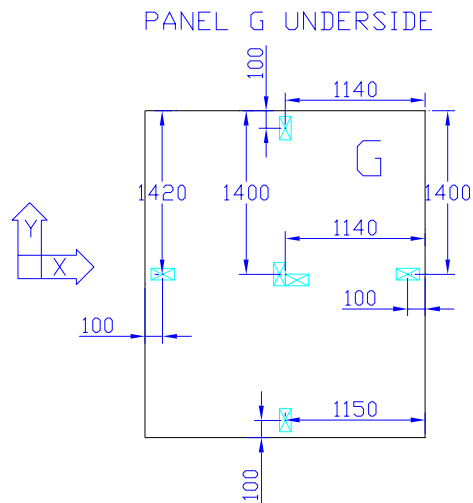

Figure 3.3 Strain gauge installations underneath panel G. The beam measurements are from the inside of the hull

3.1.2 Panel H - fore peak

The panel is located in the bulkhead between the fan compartment and the fore peak. The panel was instrumented with strain gauges on the fore peak side and a pressure sensor on the fan compartment side. The strain gauge locations are sketched in Fig 3.4, and the pressure location is sketched in Fig 3.9

3.1.3 Panel 5 and fan compartment

Panel 5 is the panel between the air inlet gratings. The measurements of the sensor locations on the top side of panel 5 are given in Fig 3.6.

The fore strain gauge had to be placed 150 mm behind the beam since the new core material extended 70 mm into panel 5. The locations of the gauges underneath panel 5 as well as those on the beams in the fan compartment are sketched in Fig 3.8.

In addition, there were pressure gauges underneath the port air inlet, in the bottom port foremost corner as well as in the middle of (the aft side of) panel H, see Fig 3.9

3.1.4 Sensor locations in the port fan engine room and port stores

The beams on which the sensors were mounted are located in port stores and and port fan engine room. Equipment in the engine room mounted complicated the installation. The sensors had to be moved away from the walls since a curved beam support was installed.

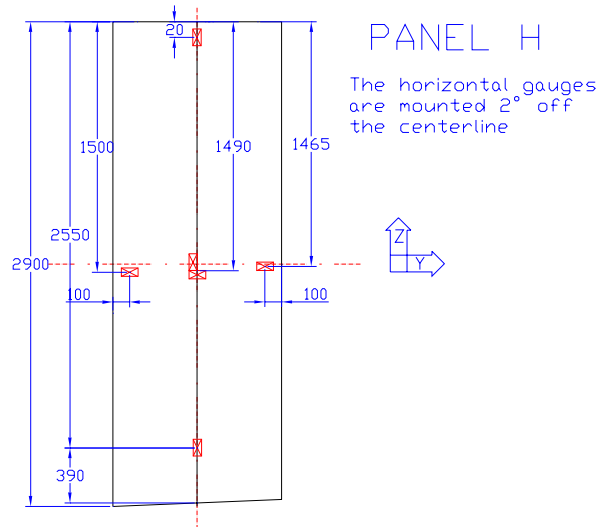

Figure 3.4 Strain gauge locations on panel H. The horizontal sensors are installed at 2° inclination angle as they were mounted parallel to the floor; later we discovered that the floor was not parallel to the ceiling. The lower sensor could not be attached closer to the floor due to other installations

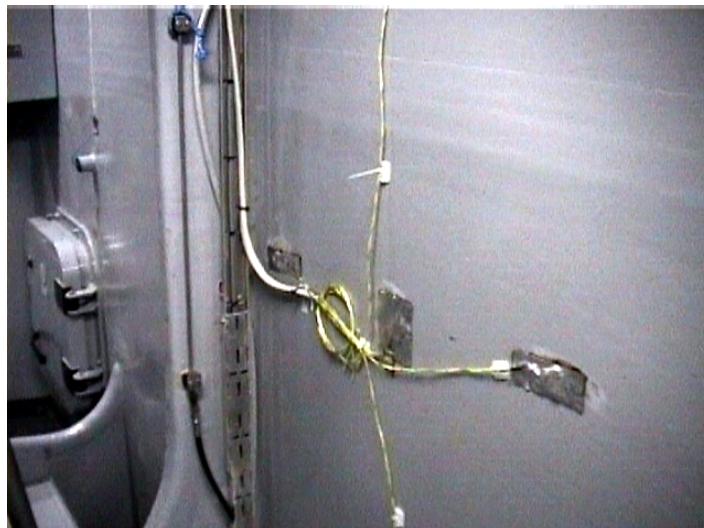

Figure 3.5 Photo of the installation on panel H.

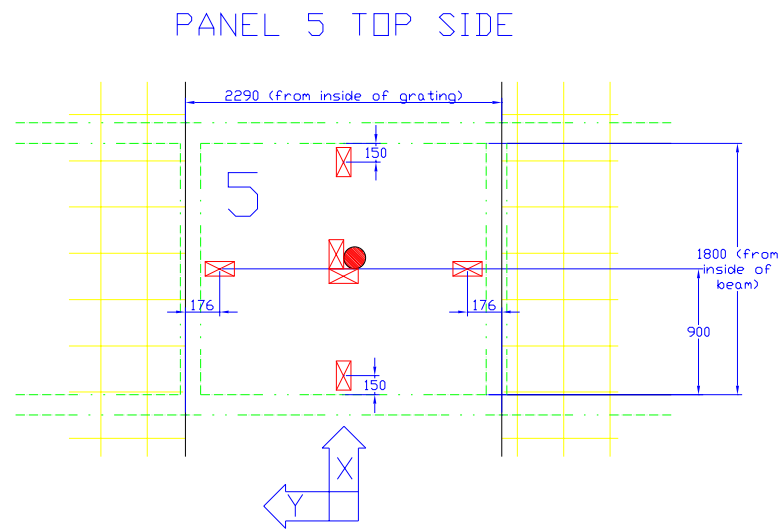

Figure 3.6 Sensor installation on the weather side of panel 5



Figure 3.7 From the installation on the weather side of panel 5

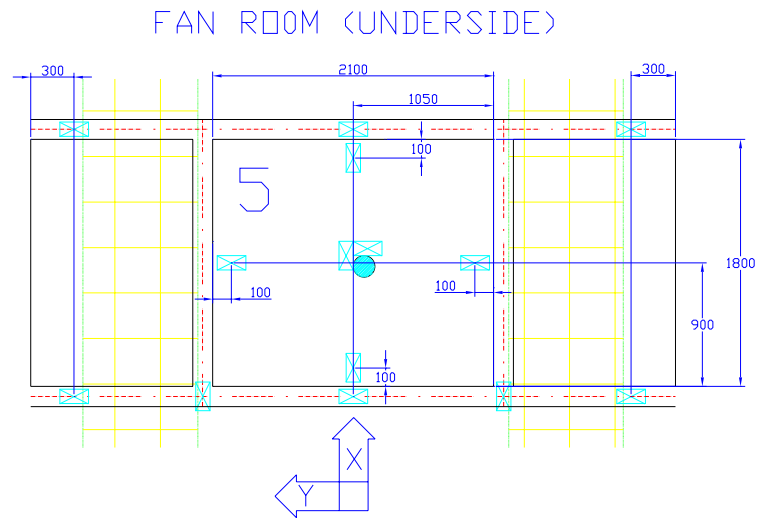

Figure 3.8 Strain gauge locations in the fan compartment ceiling and on the beams. Three pressure sensors were added in the fan compartment (see Fig below)

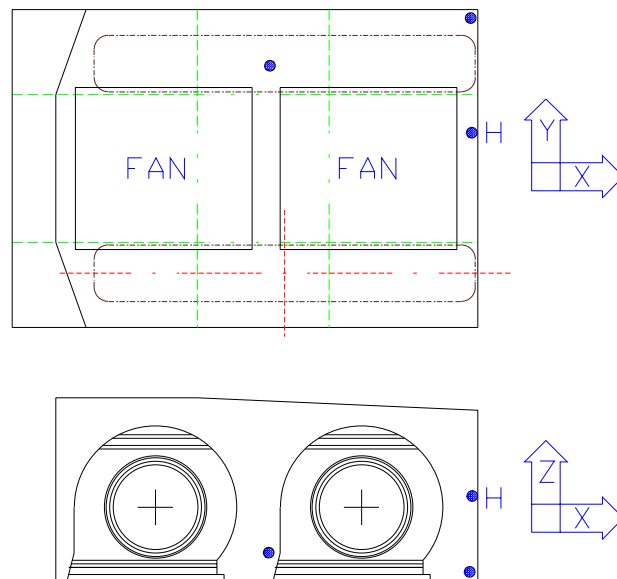

Figure 3.9 Locations of the pressure gauges in the fan compartment. The gauge beneath the air-inlet, was placed on a tripod, approximately 1m above the floor, the sensor in the corner was raised some 250 mm above the floor in order to avoid water splash, and finally the flat sensor was located in the center on the back of panel H

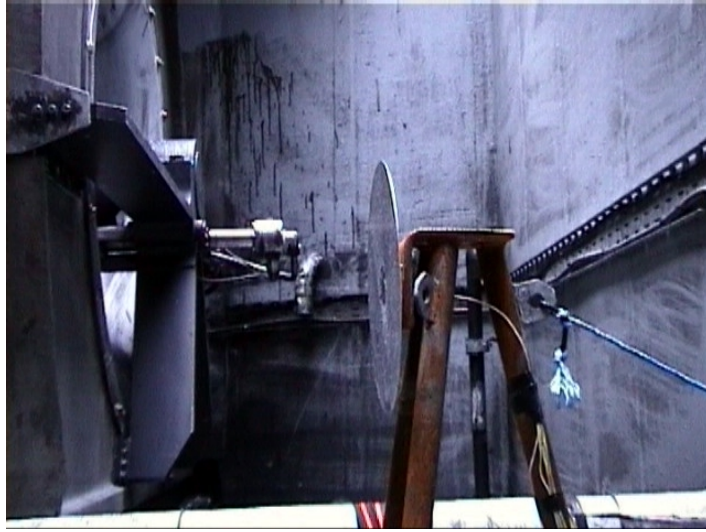

Figure 3.10 Pressure sensor P3 was mounted in a disc to avoid measuring reflection pressure of the passing shock wave

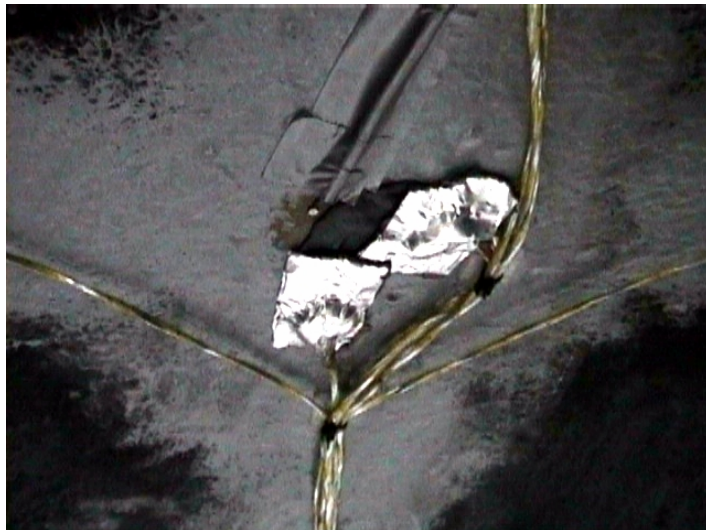

Figure 3.11 Pressure sensor P4 was mounted underneath panel 5



Figure 3.12 Pressure sensor P5 was mounted in a Styrofoam holder somewhat above the lower corner on the forward port side in the lift fan room



Figure 3.13 Pressure sensor P6 was mounted on the aft side of panel H, facing the forward lift fan

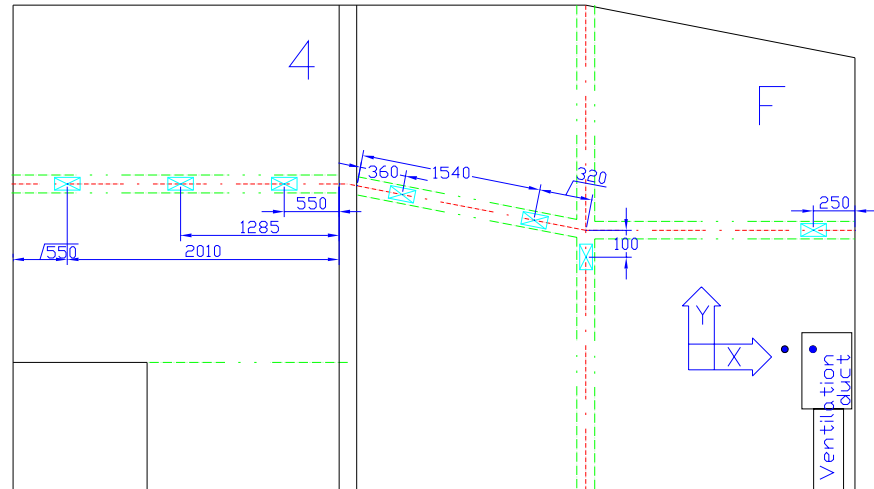

Figure 3.14 Strain gauge locations on the beams in port fan engine room and port stores. One pressure gauge is located inside the ventilation duct, whereas the other was placed on the floor directly beneath the duct

The measurements are given in Fig 3.14.

3.2 Sensors for estimation of rotations

The rotations between the gun fundament, datum and the mounting points of the weapons radar at the wheelhouse roof and the electro-optical sight in the mast were to be estimated. 5 accelerometers at each location is sufficient to calculate the rotation, see (3) for details. However, the accelerometer measurements are subject to noise, and rotation calculations are extremely sensitive to any errors (due to integration), consequently, supplementary strain measurements were made where this was possible.

3.2.1 Gun fundament

Five accelerometers were mounted on top of the fundament (on deck), see Fig 3.17. The measurements are supported with four fiber optic strain gauges on one (column 6) of the eight fundament columns. The locations are shown in Fig 3.18.

3.2.2 Wheelhouse roof

The accelerometers were installed on the pointing radar platform. Sensor locations are given in Fig 3.19.



Figure 3.15 Pressure sensor P7 was mounted in a Teflon holder. The holder was inserted in a 16 mm diameter hole in the air inlet and fixed using Sikaflex

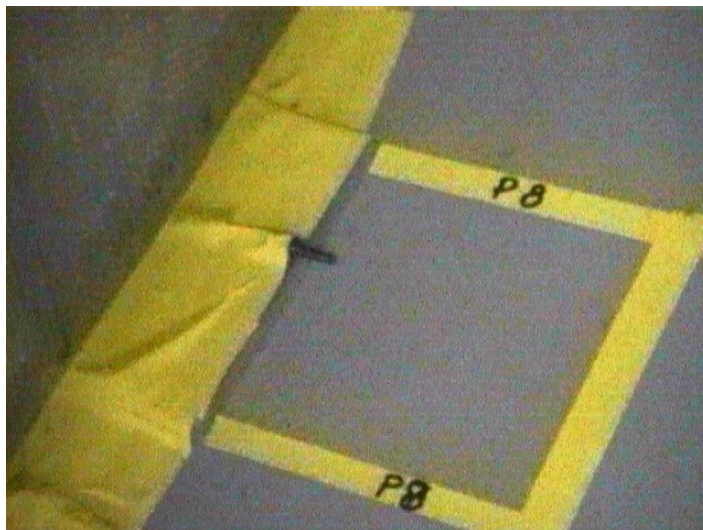

Figure 3.16 Pressure sensor P8 was placed on the floor directly beneath the sensor P7

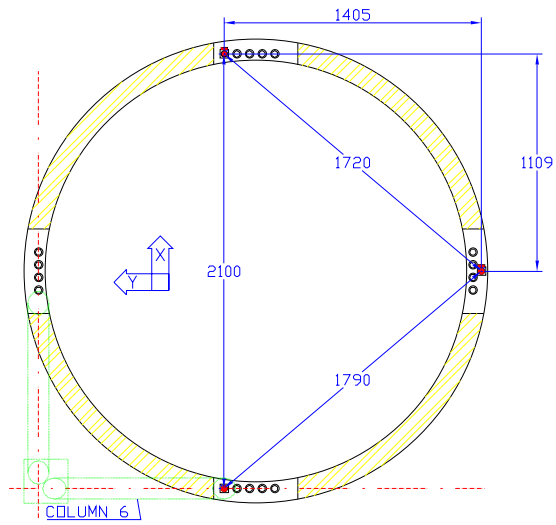

Figure 3.17 Accelerometer locations on the fundam. Measurements in the z -direction are carried out at all three locations, whereas the acceleration in the x -direction is measured at the starboard and fore locations

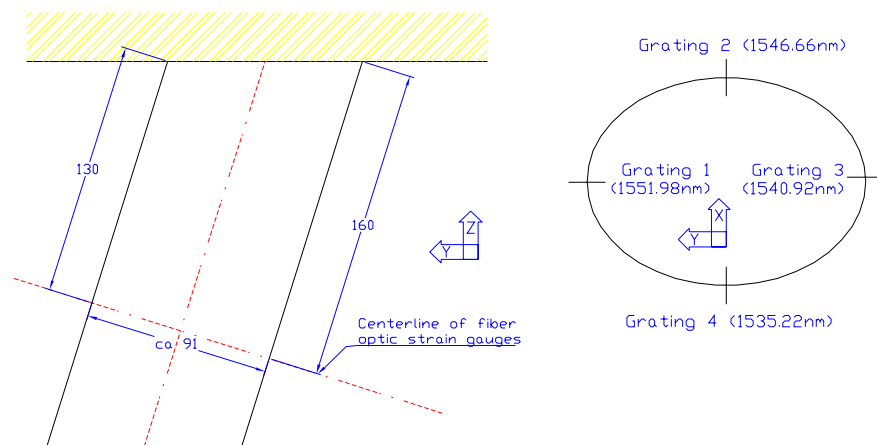

Figure 3.18 Fiber optic strain sensor locations on column 6 of the fundam

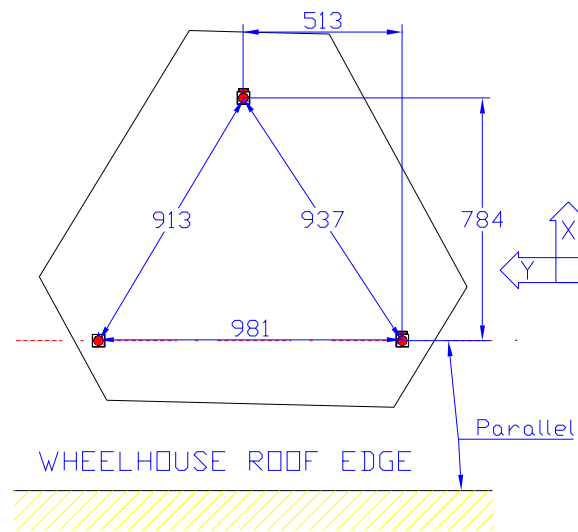

Figure 3.19 Accelerometer locations on the wheelhouse roof. The pointing radar platform was not parallel to the vessel's coordinate system, however, the aft accelerometer cubes were installed in parallel with the edge of the roof. Acceleration in the z-direction is measured at all points, whereas the x-component of the acceleration of the the starboard and port cubes were measured

3.2.3 Instrument room (datum)

A rotation measurement jig was built in order to get best possible rotation estimations. The reference surfaces were milled such that they were parallel, thus their relative positions were known accurately. Umoe Mandal provided “hats” with M8 threads for installation of the jig. The position of the threads did not allow alignment of the jig in parallel to the x- and y-axes of the vessel. For installation coordinates, see Fig 3.20.

3.2.4 Mast

A jig, identical to the one in the instrument room, was placed on top of the mast, see Fig 3.22.

In addition, the mast measurements were supported by use of 3 fiber optical sensors on each of the two legs at top bridge level. All sensors were located on the outside of the mast. Details concerning the locations are presented in Fig 3.23.

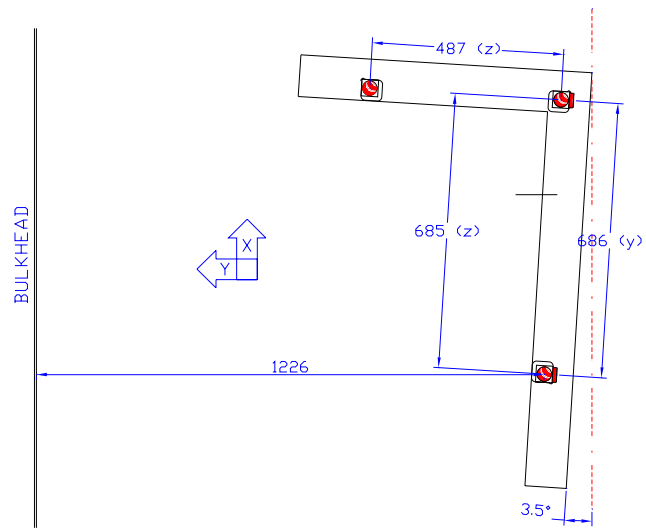

Figure 3.20 Rotation jig installation in the instrument room (datum)



Figure 3.21 Hats on the instrument room floor onto which the jig for rotation measurements was mounted

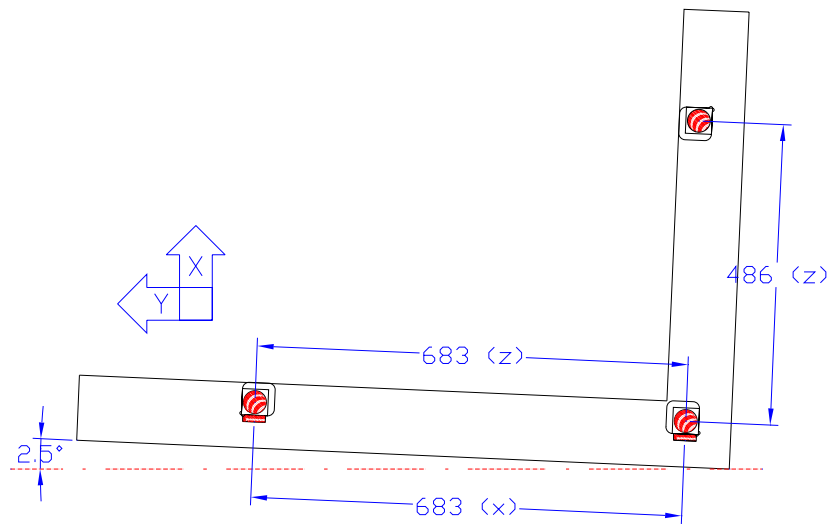

Figure 3.22 Rotation jig installation on top of the mast

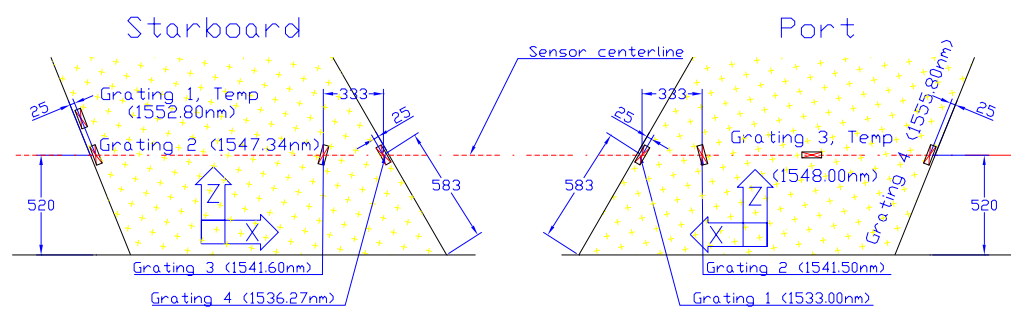

Figure 3.23 Fiber Bragg grating installation on the legs of the mast



Figure 3.24 Fiber Bragg grating installation on the starboard side mast



Figure 3.25 Fiber Bragg grating installation on the port side mast

4 COMMENTS

The second series of measurements on gun integration tests onboard KNM Skjold gave much better results than the first. The most important improvements were

- Lower noise level on strain gauge measurements
- Full set of rotation measurements obtained
- Higher sampling rate on all measurements

The strain gauge noise level was reduced chiefly because a better cable routing was available. Since we used a Wheatstone quarter-bridge configuration, any pickup of electromagnetic noise in the cable would be interpreted as a strain response. The resistance against noise would improve much using a half-bridge configuration, however, this would increase the number of cables necessary and complicate the installation. By routing the cables on deck instead of in the cable gates, a satisfactory noise level was obtained using the quarter bridge.

The rotation measurements greatly profited from the experience gained during the tests in October 1999. Aluminum jigs were used wherever possible to reduce uncertainty in accelerometer orientation. The data from the October test also enabled us to better choose the appropriate accelerometer sensitivities and avoid saturation of the highpass filters built in the accelerometer amplifiers. Since we had better time for preparation, we had also developed computer programs extracting information on the maximum values measured in each gun exercise. This allowed us to easily check the data after each exercise and optimize the accelerometer amplification for the different firing directions.

The personnel and equipment from *Forsvarets Bygningstjeneste (FBT)* were necessary to make the measurements a success. Their experience with experiments based on explosions was most helpful during preparations for the test. Their amplifiers and logging equipment allowed a sampling rate of 10 kHz, as opposed to 3 kHz during the test in October. However, their equipment is based on logging a short interval controlled by a trigger signal, and would not suffice for continuous measurements. The software and equipment from FFI can handle continuous measurements on an equivalent number (32) of sensors, but the sampling rate is limited upwards to about 15 kHz.

To complete the installation in time, the help from the ABB electricians doing the cabling, Umoe Mandal and the crew was necessary for installing the electrical strain gauges in time. The amount of cabling would have been much reduced if fiber optic strain gauges were available for the test.



Figure 4.1 The strips pads were affixed to the wall using the supplied double sided tape after cleaning with Kleener Blå

4.1 Comments on individual sensor locations

In the port fan engine room, the strain gauge cable was laid through the metal mesh covering the roof and walls. We lost two sensors in this location, and believe this is due to the mesh vibrating after the shot and destroying either the cable or the strain gauge. Cables in such locations should be better protected in later experiments.

Cabling inside the fan engine room was strapped onto strips pads. The pads were affixed using the double sided tape on the pads. After the experiments, some pads were loose. This occurred on the beams where where the pads supported several heavy cables, and on the underside of panel 5. The pads adhered well on the walls. In new experiments, affixing pads using Sikaflex should be considered in cases where heavy cable is attached or when placing pads on horizontal, wet surfaces. Surface cleaning is also important. We found that cleaning the surface with detergents, ethanol or acetone did not give satisfactory adherence. However, a cleaner spray for electronics, *Kleener Blå, Spray Master, Vallentuna, Sweden*, containing 30-60% alicyclic hydrocarbons, yielded good results.

The putty AK-22, used for protecting strain gauges, adhered well to the surfaces. However, the aluminum foil covered ABM-75 putty did partly fall off in one location under panel 5.

We spent much time cleaning the lift fan room. We recommend that the room is thoroughly cleaned to remove soot from the surfaces prior to future sensor installations.

The flat, surface mounted pressure sensors were lifted off the surface using a knife. This operation was much easier on laminate than on carbon surfaces. We recommend that a solvent, such as acetone, is applied to “soften” the glue before mechanically removing the sensors.



Figure 4.2 Some of the ABM 75 foil covered putty and strips pads fell off under panel 5. This did not affect the measurements, but should be noted in case a long-term measurement is initiated

Sensor installation was helped by KNM Skjold being inside for repair and deck replacement. This allowed us to work on dry surfaces in room temperature. We doubt that sensor installation would have been possible outdoors in winter.

References

- (1) Tjenester ifm kanonskyting med ny MTB. FFI KONTRAKT P-02/2000.
- (2) Enger E M, Jensen A E (2000): Testprogram for 2. kanontest på KNM Skjold, 70092/07-Fi-001 Rev 0, FiReCo AS.
- (3) Sagvolden G, Farsund Ø, Lundberg Ø, Pran K (2000): Displacement measurements during firing tests on KNM Skjold October 1999, FFI/NOTAT-2000/01295, Forsvarets forskningsinstitutt (Distribution limited).

APPENDIX**A DATA CDS**

The following data CDs are available at the FFI.

CD number	Description
79301-02-01	Raw data: Fibersensors (binary) Results: Strain and calculated rotations (ASCII)
79301-02-02	Raw data: Strain gauges and pressure sensors (ASCII)
79301-02-03	Raw data: Accelerometers and strain gauges panel H,F (binary)
79301-02-04	Results: Calculated rotations (ASCII, Postscript)
79301-02-05	Raw data: Transfer from test range (binary)
79301-02-06	Raw data: Transfer from test range (binary)

Table A.1 Data CDs from the cannon firing tests

DISTRIBUTION LIST

FFIE
Dato: 13 july 2000

RAPPORTTYPE (KRYSS AV)			RAPPORT NR.	REFERANSE	RAPPORTENS DATO			
<input checked="" type="checkbox"/>	RAPP	<input type="checkbox"/>	NOTAT	<input type="checkbox"/>	RR	2000/03665	FFIE/793/116	13 july 2000
RAPPORTENS BESKYTTELSESGRAD				ANTALL EKS UTSTEDT	ANTALL SIDER			
UNCLASSIFIED				41	33			
RAPPORTENS TITTEL				FORFATTER(E)				
SENSOR INSTALLATION ON KNM SKJOLD PRIOR TO FIRING TESTS APRIL 2000				FARSUND Øystein, SAGVOLDEN Geir, PRAN Karianne, WANG Gunnar				
FORDELING GODKJENT AV FORSKNINGSSJEF:				FORDELING GODKJENT AV AVDELINGSSJEF:				

EKSTERN FORDELING
INTERN FORDELING

ANTALL	EKS NR	TIL	ANTALL	EKS NR	TIL
1		SFK, Teknisk avdeling	14		FFI-Bibl
1		V/ Steinar Nilsen	1		Adm direktør/stabssjef
1		V/ Atle Sannes	1		FFIE
		Postboks 3, Haakonsværn	1		FFISYS
		5086 BERGEN	1		FFIBM
			1		FFIN
1		FiReCo AS	1		Gunnar Wang, FFIE
1		V/ Jon Taby	1		Karianne Pran, FFIE
1		V/ Alf Egil Jensen	1		Øystein Farsund, FFIE
		Mosseveien 39B	1		Geir Sagvolden, FFIE
		1610 FREDRIKSTAD			
1		Kværner Mandal AS	9		Arkiv, FFIE
1		V/ Nere Skomedal	1		FFI-veven
		Postboks 283			
		4501 MANDAL			

FFI-K1

Retningslinjer for fordeling og forsendelse er gitt i Oraklet, Bind I, Bestemmelser om publikasjoner for Forsvarets forskningsinstitutt, pkt 2 og 5. Benytt ny side om nødvendig.