

august 2015 - Design /production: FFI

## Triaxial collaboration

There are vigorous connections between the work and research carried out at FFI, and development and production in both large and small Norwegian business enterprises. The most advanced products delivered by the Norwegian defence industry have emerged from a triaxial collaboration between industry, the Armed Forces and FFI

▲ The Naval Strike Missile (NSM) launched from a Royal Norwegian Navy corvette. This missile from KONGSBERG is developed with significant contribution from FFI.

Many of the products delivered by major Norwegian defence enterprises have emerged from a close collaboration between the industry itself, FFI, and the Armed Forces as the client and user. This “triaxial collaboration” was adopted in the early postwar period, with the anti-submarine weapon Terne in the 1950s as a good example. The triaxial model has since been used successfully a number of times. Anti-ship missiles, air defence, ammunition, and rocket engines are some examples. The model has been pivotal in building up the national defence industrial expertise.

The triaxial collaboration model is widely used in other comparable countries as well. It has often proved to be useful and productive

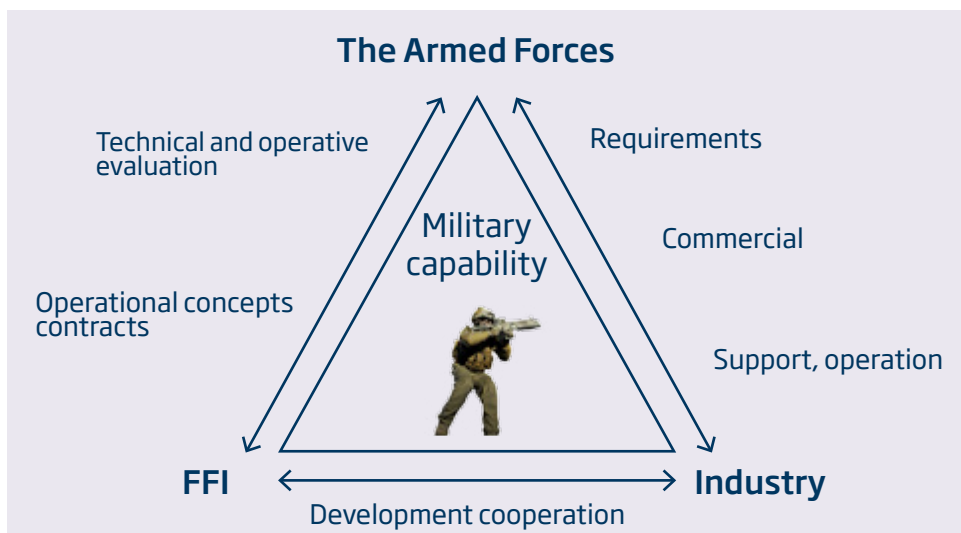

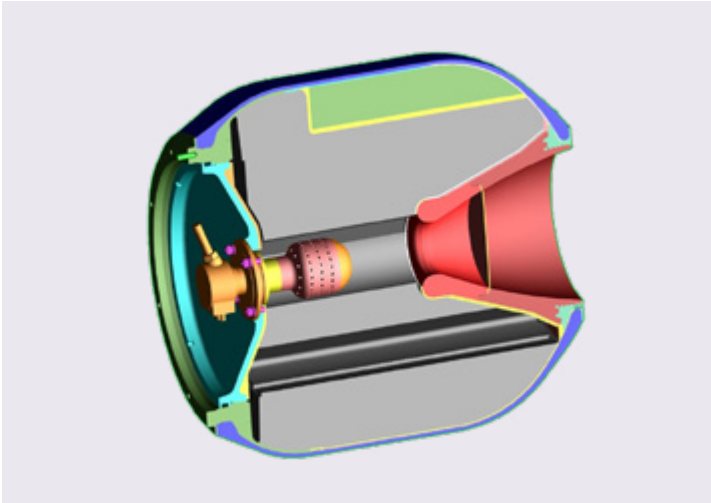

▲ The Naval Strike Missile booster is developed by Nammo and FFI.



▲ FFI and Norwegian industry have developed HUGIN, one of the world's most advanced autonomous underwater vehicles.

for a small country like Norway, where the communication lines are short and effective. Norway has little opportunity to duplicate expertise. The collaboration model can help the nation utilise its combined expertise optimally. This requires that the different roles are clarified, that cost-effectiveness is the guiding requirement, and that the ethical guidelines are followed.

### Innovative power in cooperation

FFI plays an active role in laying the foundations for further development of the Armed Forces and the ability of Norwegian defence to meet future military challenges and issues of national security.

Science and technology are the central driving forces in the development of modern society in general and the defence sector in particular. FFI is the defence sector's principle professional research arm in the areas of technical and scientific development and expertise. The Norwegian defence sector's collaborative work with FFI lays the foundation for further development of the Armed Forces. Moreover, it strengthens the ability of the Norwegian defence to meet future military and security related challenges.

This is hardly a new situation for the Institute. When FFI was founded in 1946, it was in recognition of two key points – that technology had played a decisive role in the outcome of the Second World War, and that the Norwegian Armed Forces had been insufficiently aware of technology's role in modern warfare. Upon its establishment, FFI was commissioned with three primary goals: FFI would play a

vital role in both the modernisation of the Norwegian Armed Forces, the modernisation of Norwegian national industry and of the scientific community in Norway. Upon assessing FFI's status almost 70 years later, FFI has clearly delivered in all three areas. This is best expressed by the fact that Norway now possesses a modern, technologically advanced and effective defence. For FFI this is and will always be the most important thing.

### Contribute to industrial development

FFI's bylaws state that the Institute shall, in so far as it is compatible with its other purposes, contribute to industrial and technological development in Norway. In this capacity, it should take on projects in collaboration with civilian authorities and with national business and industry. There are vigorous connections between the work and research carried out at FFI, and development and production in both large and small Norwegian business enterprises. The most advanced products delivered by the Norwegian defence industry have emerged from a triaxial collaboration between industry, the Armed Forces and FFI. The result of this cooperation is a highly competent, modern and competitive Norwegian defence industry with sales that have more than doubled since 2004.

### Challenge and strengthen each other

The defence sector benefits greatly from the existence of a competitive defence industry capable not only of delivering apace with Armed Forces needs, but that also offers the best price, quality and performance - while simultaneously succeeding in the international market. In a time of considerable economic

turmoil throughout much of Europe and in an increasingly more competitive international market, the need for innovative thought is great. The ability to capitalise on the innovative power of the triaxial cooperation will be important to ensuring success throughout these demanding times. Further development of this model will enable all three parties to continue challenging and strengthening each other, while simultaneously securing highly competent workplaces and important technology with wide applicability to the civilian sector.

### The research triangle

This approach is in line with how the European Union (EU) is directing its future knowledge and industrial policy, towards what is called 'the knowledge triangle' – education, research and innovation. The EU's strategy takes into account the fact that Europe can no longer assert itself in terms of cost-competitiveness, but must instead have innovation and knowledge-based industry in focus. This means that European products and services must be characterised by higher levels of knowledge and a greater content of innovation than products and services from other parts of the world. One criteria for success is the possession of an outstanding research community. For FFI this means continuing to deliver useful results of outstanding professional quality. To that end, the Institute will always strive to recruit the best talent, further develop our most comprehensive international collaborations and ceaselessly assure the quality of our professional expertise.